

EP50S Series

Diameter ø50mm Shaft type Absolute Rotary Encoder

■ Features

- Compact size of external diameter ø50mm
- Various output code: BCD, Binary, Gray code
- Various and high resolution(720, 1024 divisions)
- Protection structure IP64(Dust-proof, Oil-proof)

■ Applications

- Precision machine tool, Fabric machinery, Robot, Parking system



⚠ Please read "Caution for your safety" in operation manual before using.



■ Ordering information

EP50S	8	-	1024	-	1	-	R	-	P	-	24
Series	Shaft diameter	Pulse/1Revolution	Output code	Revolution direction	Control output	Power supply					
Diameter ø50mm shaft type	ø8mm	Refer to resolution	1 : BCD Code 2 : Binary Code 3 : Gray Code	F : Output value increase at CW direction R : Output value increase at CCW direction	P : PNP open collector output N : NPN open collector output	5 : 5VDC ±5% 24 : 12-24VDC ±5%					

■ Specifications

Item		Diameter ø50mm shaft type of absolute rotary encoder											
Resolution		6, 8, 10, 12, 16, 20, 24, 32, 40, 45, 48, 64, 90, 128, 180, 256, 360, 512, 720, 1024											
Output code		BCD Code		Binary Code		Gray Code		BCD Code		Binary Code		Gray Code	
Electrical specification	Output phase / Output angle ^{※1}	1024-division	TS: 0.3515°±15' (13bit)	TS: 0.3515°±15' (10bit)	TS: 0.703°±15' (10bit)	20-division	TP1:12°±60'(1bit) TP2:2°±60'(1bit) TS: 18°±60'(5bit) EP: 18°±60'(1bit)	TP1: 12°±60'(1bit) TP2: 2°±60'(1bit) TS: 18°±60'(5bit) EP: 18°±60'(1bit)	TP1: 12°±60'(1bit) TP2: 2°±60'(1bit) TS: 36°±60'(5bit) EP:18°±60'(1bit)				
		720-division	TS: 0.5°±25' (11bit)	TS: 0.5°±25' (10bit)	TS: 1°±25' (10bit)		16-division	TP1: 15°±60'(1bit) TP2:2°±60'(1bit) TS: 22.5°±60' (5bit) EP: 22.5°±60' (1bit)	TP1:15°±60'(1bit) TP2:2°±60'(1bit) TS: 22.5°±60' (4bit) EP: 22.5°±60' (1bit)	TP1:15°±60'(1bit) TP2: 2°±60'(1bit) TS:45°±60'(4bit) EP: 22.5°±60' (1bit)			
		512-division	TS: 0.703°±15' (11bit)	TS: 0.703°±15' (9bit)	TS: 1.406°±15' (9bit)			12-division	TP1:15°±60'(1bit) TP2:3°±60'(1bit) TS:30°±60'(5bit) EP:30°±60'(1bit)	TP1: 15°±60'(1bit) TP2: 3°±60'(1bit) TS: 30°±60'(4bit) EP: 30°±60'(1bit)	TP1: 15°±60'(1bit) TP2: 3°±60'(1bit) TS: 60°±60'(4bit) EP: 30°±60'(1bit)		
		360-division	TS: 1°±25'(10bit)	TS: 1°±25'(9bit)	TS: 2°±25'(9bit)				10-division	TP1:30°±60'(1bit) TP2: 12°±60'(1bit) TS: 36°±60'(4bit) EP: 36°±60'(1bit)	TP1: 30°±60'(1bit) TP2: 12°±60'(1bit) TS: 36°±60'(4bit) EP: 36°±60'(1bit)	TP1: 30°±60'(1bit) TP2: 12°±60'(1bit) TS: 72°±60'(4bit) EP: 36°±60'(1bit)	
		256-division	TS: 1.406°±15' (10bit)	TS: 1.406°±15' (8bit)	TS: 2.8125°±15' (8bit)	10-division				TP1:7°±60'(1bit) TP2: 2°±60'(1bit) TS: 11.25°±60'(6bit) EP: 11.25°±60'(1bit)	TP1: 7°±60'(1bit) TP2: 2°±60'(1bit) TS: 22.5°±60'(5bit) EP: 11.25°±60'(1bit)	TP1: 7°±60'(1bit) TP2: 2°±60'(1bit) TS: 45°±60'(3bit) EP: 45°±60'(1bit)	
		180-division	TS: 2°±25'(9bit)	TS: 2°±25'(8bit)	TS: 4°±25'(8bit)		6-division			TP1:5°±60'(1bit) TP2: 2°±60'(1bit) TS: 9°±60'(6bit) EP: 9°±60'(1bit)	TP1: 5°±60'(1bit) TP2: 2°±60'(1bit) TS: 9°±60'(6bit) EP: 9°±60'(1bit)	TP1: 5°±60'(1bit) TP2: 2°±60'(1bit) TS: 18°±60'(6bit) EP: 9°±60'(1bit)	
		128-division	TS: 2.8125°±15' (9bit)	TS: 2.8125°±15' (7bit)	TS: 5.625°±15' (7bit)			6-division		TP1:8°±60'(1bit) TP2: 3°±60'(1bit) TS: 15°±60'(6bit) EP: 15°±60'(1bit)	TP1: 8°±60'(1bit) TP2: 3°±60'(1bit) TS: 15°±60'(6bit) EP: 15°±60'(1bit)	TP1: 8°±60'(1bit) TP2: 3°±60'(1bit) TS: 30°±60'(6bit) EP: 15°±60'(1bit)	
		90-division	TS: 4°±25'(8bit)	TS: 4°±25'(7bit)	TS: 8°±25'(7bit)				6-division	TP1:15°±60'(1bit) TP2: 15°±60'(1bit) TS: 60°±60'(3bit) EP: 60°±60'(1bit)	TP1: 15°±60'(1bit) TP2: 15°±60'(1bit) TS: 60°±60'(3bit) EP: 60°±60'(1bit)	TP1: 15°±60'(1bit) TP2: 15°±60'(1bit) TS: 120°±60'(3bit) EP: 60°±60'(1bit)	
		64-division	TS: 5.625°±15'(7bit)	TS: 5.625°±15'(6bit)	TS: 11.25°±15'(6bit)	6-division				TP1:5°±60'(1bit) TP2: 2°±60'(1bit) TS: 9°±60'(6bit) EP: 9°±60'(1bit)	TP1: 5°±60'(1bit) TP2: 2°±60'(1bit) TS: 9°±60'(6bit) EP: 9°±60'(1bit)	TP1: 5°±60'(1bit) TP2: 2°±60'(1bit) TS: 18°±60'(6bit) EP: 9°±60'(1bit)	
		48-division	TS: 7.5°±25'(7bit)	TS: 7.5°±25'(6bit)	TS: 15°±25'(6bit)		6-division			TP1:30°±60'(1bit) TP2: 12°±60'(1bit) TS: 36°±60'(4bit) EP: 36°±60'(1bit)	TP1: 30°±60'(1bit) TP2: 12°±60'(1bit) TS: 36°±60'(4bit) EP: 36°±60'(1bit)	TP1: 30°±60'(1bit) TP2: 12°±60'(1bit) TS: 72°±60'(4bit) EP: 36°±60'(1bit)	
		45-division	TS: 8°±25'(7bit)	TS: 8°±25'(6bit)	TS: 16°±25'(6bit)			6-division		TP1:15°±60'(1bit) TP2: 3°±60'(1bit) TS: 30°±60'(4bit) EP: 30°±60'(1bit)	TP1: 15°±60'(1bit) TP2: 3°±60'(1bit) TS: 30°±60'(4bit) EP: 30°±60'(1bit)	TP1: 15°±60'(1bit) TP2: 3°±60'(1bit) TS: 60°±60'(4bit) EP: 30°±60'(1bit)	
		40-division	TP1: 5°±60'(1bit) TP2: 2°±60'(1bit) TS: 9°±60'(6bit) EP: 9°±60'(1bit)	TP1: 5°±60'(1bit) TP2: 2°±60'(1bit) TS: 9°±60'(6bit) EP: 9°±60'(1bit)	TP1: 5°±60'(1bit) TP2: 2°±60'(1bit) TS: 18°±60'(6bit) EP: 9°±60'(1bit)				6-division	TP1:39°±60'(1bit) TP2: 15°±60'(1bit) TS: 45°±60'(3bit) EP: 45°±60'(1bit)	TP1: 39°±60'(1bit) TP2: 15°±60'(1bit) TS: 45°±60'(3bit) EP: 45°±60'(1bit)	TP1: 39°±60'(1bit) TP2: 15°±60'(1bit) TS: 90°±60'(3bit) EP: 45°±60'(1bit)	
		32-division	TP1:7°±60'(1bit) TP2: 2°±60'(1bit) TS: 11.25°±60'(6bit) EP: 11.25°±60'(1bit)	TP1:7°±60'(1bit) TP2: 2°±60'(1bit) TS: 11.25°±60'(5bit) EP: 11.25°±60'(1bit)	TP1: 7°±60'(1bit) TP2: 2°±60'(1bit) TS: 22.5°±60'(5bit) EP: 11.25°±60'(1bit)	6-division				TP1:53°±60'(1bit) TP2: 15°±60'(1bit) TS: 60°±60'(3bit) EP: 60°±60'(1bit)	TP1: 53°±60'(1bit) TP2: 15°±60'(1bit) TS: 60°±60'(3bit) EP: 60°±60'(1bit)	TP1: 53°±60'(1bit) TP2: 15°±60'(1bit) TS: 120°±60'(3bit) EP: 60°±60'(1bit)	
		24-division	TP1: 8°±60'(1bit) TP2: 3°±60'(1bit) TS: 15°±60'(6bit) EP: 15°±60'(1bit)	TP1: 8°±60'(1bit) TP2: 3°±60'(1bit) TS: 15°±60'(5bit) EP: 15°±60'(1bit)	TP1: 8°±60'(1bit) TP2: 3°±60'(1bit) TS: 30°±60'(5bit) EP: 15°±60'(1bit)		6-division			TP1:53°±60'(1bit) TP2: 15°±60'(1bit) TS: 60°±60'(3bit) EP: 60°±60'(1bit)	TP1: 53°±60'(1bit) TP2: 15°±60'(1bit) TS: 60°±60'(3bit) EP: 60°±60'(1bit)	TP1: 53°±60'(1bit) TP2: 15°±60'(1bit) TS: 120°±60'(3bit) EP: 60°±60'(1bit)	
Control output	PNP open collector output	Output voltage : Min. (Power supply-1.5)VDC, Load current : Max. 32mA											
	NPN open collector output	Load current : Max. 32mA, Residual voltage : Max. 1VDC											
Response time(Rise/Fall)	Ton=800nsec, Toff=Max. 800nsec(Cable length : 2m, I sink = 32mA)												
Max. Response frequency	35kHz												
Power supply	• 5VDC ±5%(Ripple P-P : Max. 5%) • 12-24VDC ±5%(Ripple P-P : Max. 5%)												
Current consumption	Max. 100mA(disconnection of the load)												
Insulation resistance	Min. 100MΩ(at 500VDC megger between all terminals and case)												
Dielectric strength	750VAC 50/60Hz for 1 minute(Between all terminals and case)												
Connection	Cable type(Cable gland)												

※1: TS=Signal Pulse, Tp=Timing Pulse, EP=Even Parity

ø50mm Shaft Absolute type

Specifications

Item	Diameter ø50mm shaft type of absolute rotary encoder	
Mechanical specification	Starting torque	Max. 40gf·cm(0.004N·m)
	Moment of inertia	Max. 40g·cm ² (4×10 ⁻⁶ kg·m ²)
	Shaft loading	Radial : 10kgf, Thrust : 2.5kgf
	Max. allowable revolution	3000rpm
Vibration	1.5mm amplitude or 300m/s ² at frequency of 10 to 55Hz(for 1 min.) in each of X, Y, Z directions for 2 hours	
Shock	Approx. Max. 50G	
Environment	Ambient temperature	-10 to 70°C, storage : -25 to 85°C
	Ambient humidity	35 to 85%RH, storage : 35 to 90%RH
Protection	IP64(IEC standard)	
Cable	ø7, 15-wire, Length : 2m, Shield cable(AWG 28, Core diameter: 0.08mm, Number of cores: 40, Insulator out diameter: 5.08)	
Accessory	Fixing bracket, Coupling	
Approval	CE	
Unit weight	Approx. 380g	

※2: Make sure that. Max response revolution should be lower than or equal to max. allowable revolution when selecting the resolution.

$$[\text{Max. response revolution(rpm)}] = \frac{\text{Max. response frequency}}{\text{Resolution}} \times 60 \text{ sec}$$

※Environment resistance is rated at no freezing or condensation.

Output waveform

• 24 division (BCD code output)

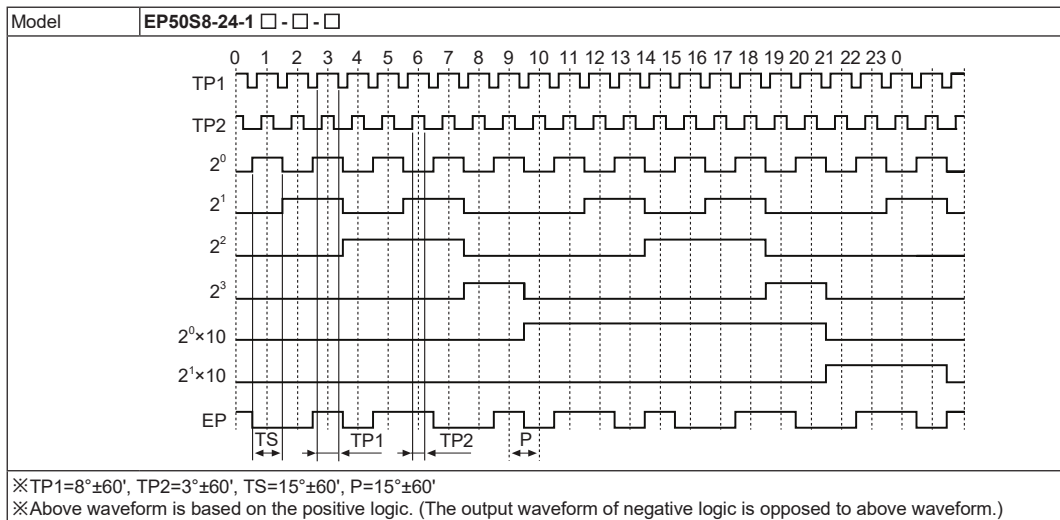

• 24 division (Binary code output)

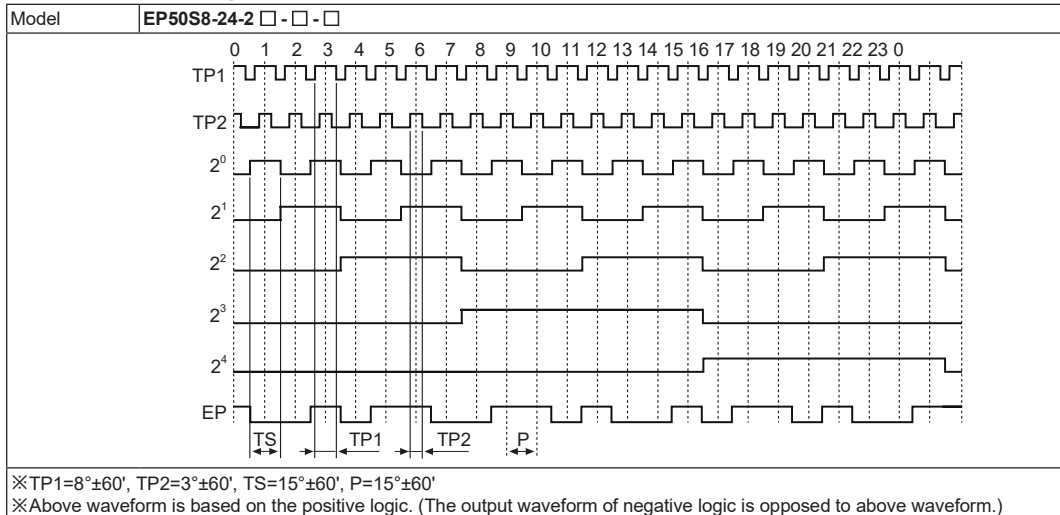

- (A) Photo electric sensor
- (B) Fiber optic sensor
- (C) Door/Area sensor
- (D) Proximity sensor
- (E) Pressure sensor
- (F) Rotary encoder
- (G) Connector/Socket
- (H) Temp. controller
- (I) SSR/ Power controller
- (J) Counter
- (K) Timer
- (L) Panel meter
- (M) Tacho/ Speed/ Pulse meter
- (N) Display unit
- (O) Sensor controller
- (P) Switching mode power supply
- (Q) Stepper motor& Driver&Controller
- (R) Graphic/ Logic panel
- (S) Field network device
- (T) Software
- (U) Other

EP50S Series

Output waveform

• 360 division (BCD code output)

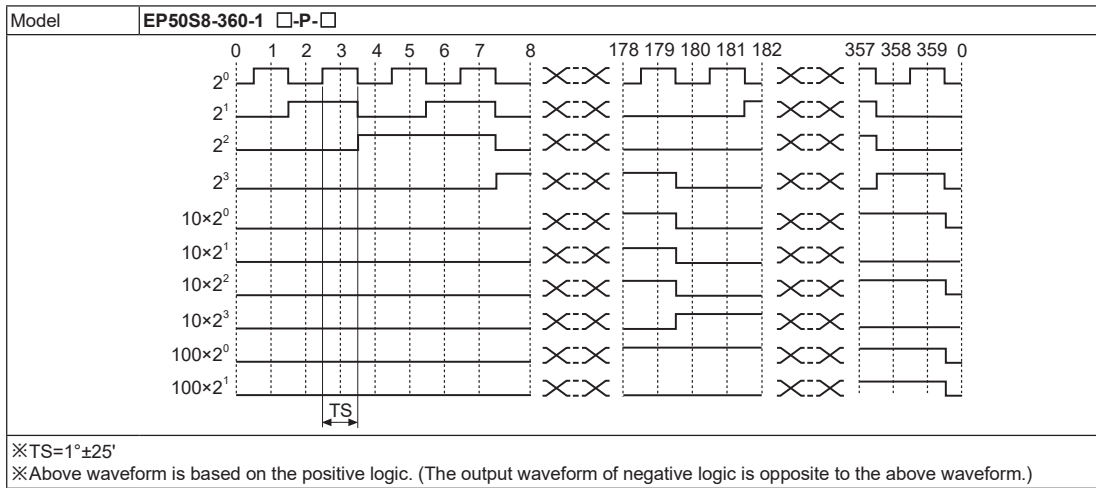

• 360 division (Binary code output)

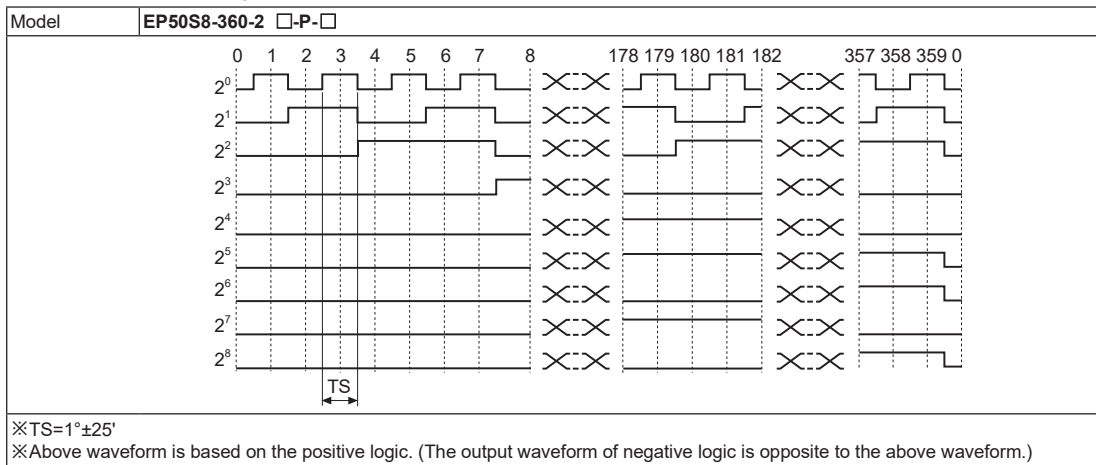

• 1024 division (BCD code output)

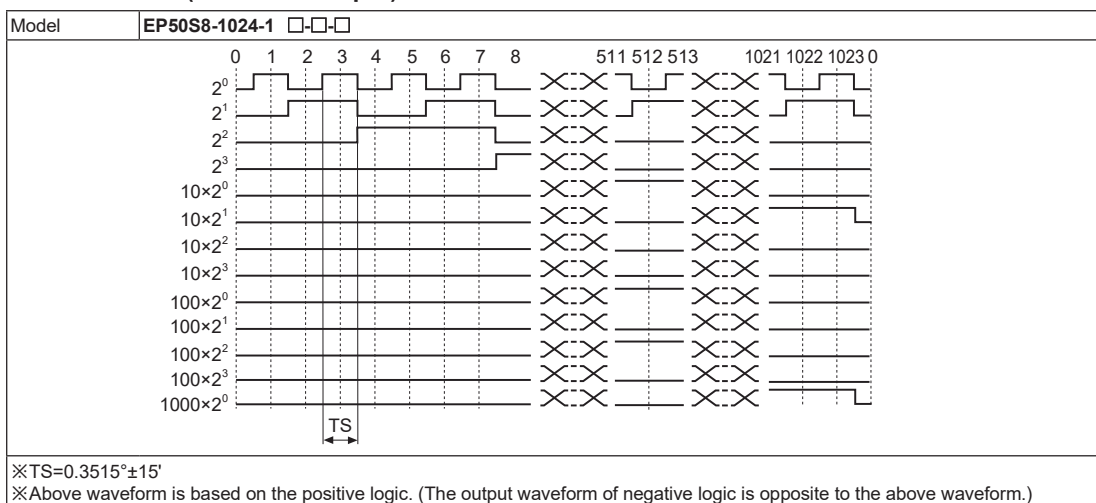

ø50mm Shaft Absolute type

Output waveform

• 1024 division (Binary code output)

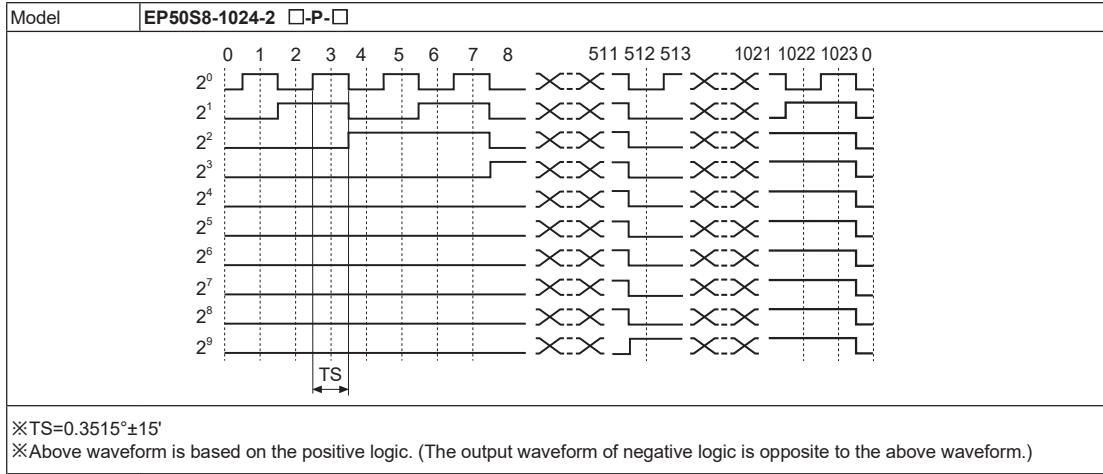

Control output diagram

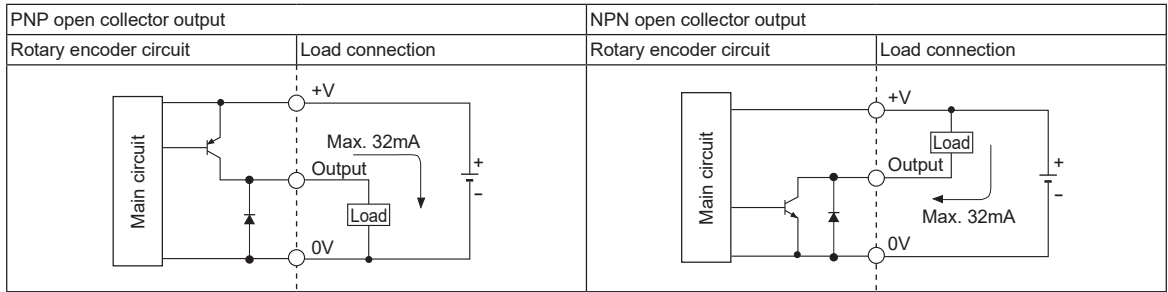

Connections

• BCD Code

Resolution	6-division	8-division	10-division	12-division	16-division	20-division	24-division	32-division	40-division	45-division	48-division	64-division	90-division	128-division	80-division	256-division	360-division	512-division	720-division	1024-division
Color	White	+V																		
Power	Black	0V																		
Output wire	Brown	2 ⁰																		
	Red	2 ¹																		
	Orange	2 ²																		
	Yellow	N-C		2 ³																
	Blue	N-C			2 ⁹ ×10															
	Purple	N-C				2 ²¹ ×10														
	Gray	N-C						2 ² ×10												
	White/Brown	TP1								2 ³ ×10										
	White/Red	TP2											2 ⁰ ×10							
	White/Orange	EP												2 ¹ ×100						
	White/Yellow	N-C														2 ² ×100				
	White/Blue	N-C																2 ³ ×100		
	White/Purple	N-C																	2 ⁰ ×1000	
Shield wire	F.G.																			

- ※Unused wires must be insulated.
- ※Encoder case and shield wire must be grounded(F.G.).
- ※N-C: Not Connected.
- ※Output cable must not be short-circuited, because Driver IC is used in output circuit.

- (A) Photo electric sensor
- (B) Fiber optic sensor
- (C) Door/Area sensor
- (D) Proximity sensor
- (E) Pressure sensor
- (F) Rotary encoder
- (G) Connector/Socket
- (H) Temp. controller
- (I) SSR/ Power controller
- (J) Counter
- (K) Timer
- (L) Panel meter
- (M) Tacho/ Speed/ Pulse meter
- (N) Display unit
- (O) Sensor controller
- (P) Switching mode power supply
- (Q) Stepper motor& Driver&Controller
- (R) Graphic/ Logic panel
- (S) Field network device
- (T) Software
- (U) Other

EP50S Series

■ Connections

● Binary Code/Gray Code

Resolution	6-division	8-division	10-division	12-division	16-division	20-division	24-division	32-division	40-division	45-division	48-division	64-division	90-division	128-division	80-division	256-division	360-division	512-division	720-division	1024-division	
Color																					
Power	White	+V																			
	Black	0V																			
Output wire	Brown	2 ⁰																			
	Red	2 ¹																			
	Orange	2 ²																			
	Yellow	N-C		2 ³																	
	Blue	N-C				2 ⁴															
	Purple	N-C								2 ⁵											
	Gray	N-C												2 ⁶							
	White/Brown	TP1										N-C					2 ⁷				
	White/Red	TP2										N-C					2 ⁸				
	White/Orange	EP										N-C					2 ⁹				
	Shield wire	F.G.																			

※Unused wires must be insulated.

※Encoder case and shield wire must be grounded(F.G.).

※N-C: Not Connected.

※Output cable must not be short-circuited, because Driver IC is used in output circuit.

■ Dimensions

(unit: mm)

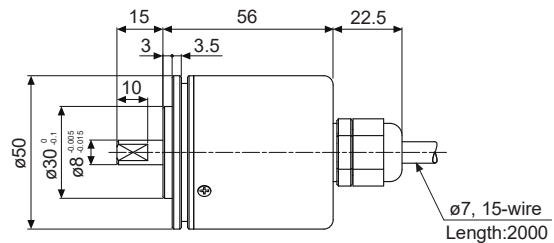
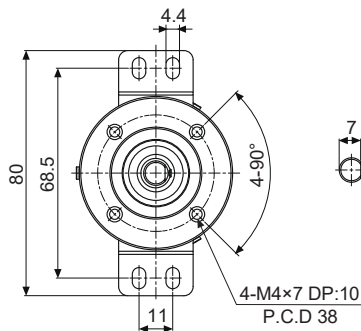

● Bracket

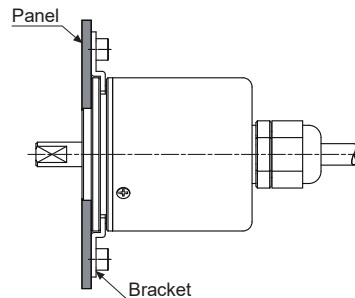
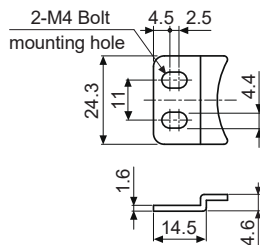

● Coupling(EP50S)

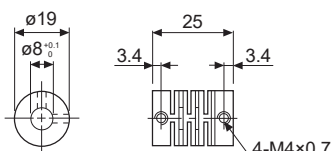

• Parallel misalignment : Max. 0.25mm

• Angular misalignment : Max. 5°

• End-play : Max. 0.2mm

※For parallel misalignment, angular misalignment, end-play terms, refer to the F-78 page.

※For flexible coupling(ERB Series) information, refer to the F-71 page.